

# THE CRYSTAL BALL AND TAPS DETECTORS AT THE MAMI ELECTRON BEAM FACILITY

DANIEL WATTS FOR THE CRYSTALBALL@MAMI AND A2-COLLABORATION

*School of Physics, University of Edinburgh, Kings' Buildings  
Edinburgh, EH9 3JZ, UK*

The Crystal Ball and TAPS detector systems will provide a highly segmented photon and hadron calorimeter for the upgraded MAMI electron beam facility. The capabilities of these detectors and upgrades in electronics and readout for the two systems are discussed.

## 1. MAMI Facility

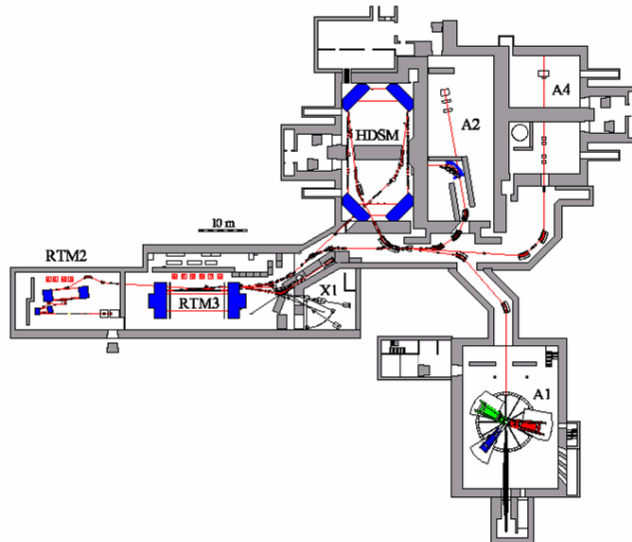

Figure 1. Schematic plan of the MAMI electron beam facility in Mainz, Germany.

The MAMI-B[1] electron beam facility produces a 0.85 GeV high quality  $\sim 100\%$  duty factor electron beam. In 2005 the facility will be upgraded to MAMI-C[2] (Figure 1) which will involve the inclusion of a further microtron stage to give an output beam energy of  $\sim 1.5$  GeV.

The MAMI electron beam can be passed to 4 experimental halls. The Crystal Ball[3] and TAPS[4] calorimeters will be used in the real photon hall (A2 on

Figure 1). In this hall the electron beam is converted to an intense ( $\sim 10^8 \gamma \text{ sec}^{-1}$ ) beam of real photons through bremsstrahlung in a thin metal foil radiator. The scattered electrons in this process are momentum analysed in the Glasgow Tagger, a magnetic spectrometer[5] which provides a determination of the energy of the associated bremsstrahlung photon with a resolution of  $\sim 2\text{MeV}$  for an incoming electron beam of  $0.85 \text{ GeV}$ . Improved resolution and rate can be achieved for smaller sub ranges of photon energy by using a more highly segmented focal plane “microscope” sub-detector system[6]. The photon beam can be produced with a high degree of linear (75%) or circular (85%) photon polarisation.

## 2. Crystal Ball

The Crystal Ball was conceived in the mid 1970s at SLAC and has been involved in experiments at SPEAR, DORIS and Brookhaven National Laboratory before arriving at MAMI. The Crystal Ball is a 672 element NaI detector covering  $\sim 94\%$  of  $4\pi$ . Each element is shaped like a truncated pyramid  $\sim 41\text{cm}$  long (Figure 3). Photons incident on the ball produce an electromagnetic shower which generally deposits energy in a number of crystals (98% of the deposited energy of each photon is contained in a cluster of 13 crystals). From analysing the centre of gravity of the shower angular resolutions for the photon of  $\sim 2\text{-}3^\circ$  in theta and  $2^\circ/\sin\theta$  in phi are achieved. The high light output of NaI also permits a good determination of the photon energy ( $\sigma/E\gamma \sim 1.7\%/E\gamma(\text{GeV})^{0.4}$ ).

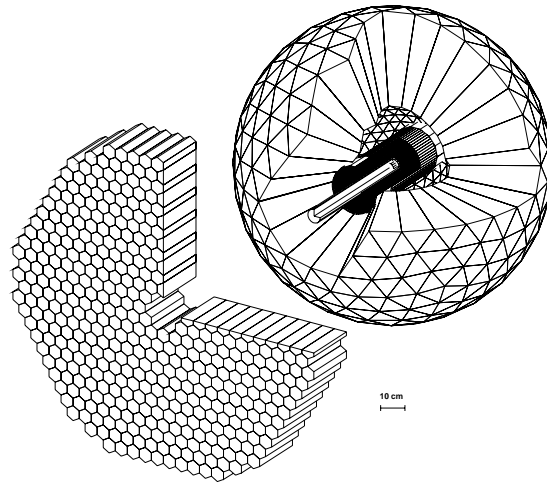

Figure 2. The Crystal Ball and TAPS detectors

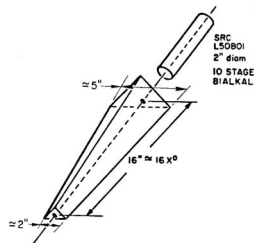

Figure 3. A single Crystal Ball element

There has been a complete overhaul of the electronics for the Crystal Ball with its move to Mainz[7]. The upgraded system is shown schematically in Figure 4. The scintillation light deposited in each crystal is read by its own 2 inch Photomultiplier tube (PMT) (Figure 3). The output signal from each PMT is fed to a split-delay module. These were designed and built for the CB experiment, based on the design of electronics used with the WASA detector at CELSIUS in Uppsala. One output branch gives analogue sums of 4 or 16 crystals which can be used in trigger decisions. The second output branch of the split feeds individual multi hit TDCs and scalers via a PM98 dual threshold

discriminator[8]. The third output branch is fed to a sampling ADC (i-SADC108032) which samples the pulse shape at 40 MHz. The ADC modules have an 80 MHz sampling capability which may be exploited in the future. Although the full sample of the pulse shape can be digitised and read out into the data stream, for the first round of experiments only the integral of the sampled signal is recorded. This integrated signal is output for three time regions - before, during and after the scintillation pulse. This enables correction for remnant light present in the crystals before the event of interest to be corrected for, which improves the energy resolution.

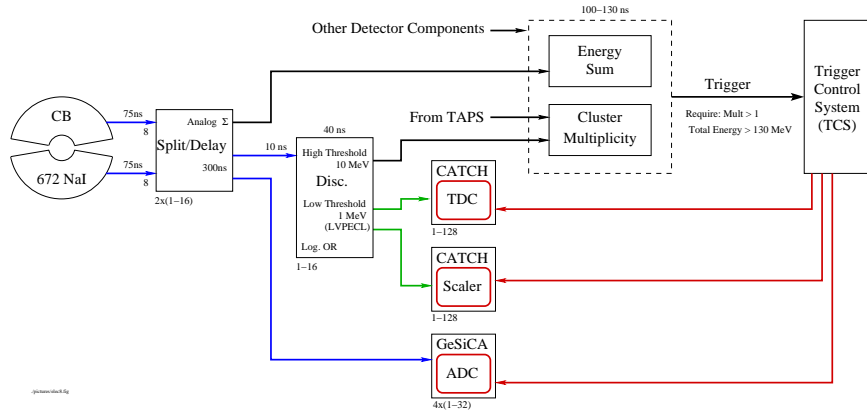

Figure 4. Schematic of the new electronic readout for the Crystal Ball

The controller boards for the ADC, TDC and scaler use the GeSiCA and CATCH electronics developed for the Compass experiment at CERN. These are presently read on VME bus via 2 PowerPC CPUs but the optical S-link readout capability will be exploited in the future to increase the readout capability. The new electronics is operational and started taking its first data early in 2004.

### 2.1. Particle identification and vertex detectors for Crystal Ball.

The photon calorimetry capabilities of the Crystal Ball have been well established. The detector has had a more limited history in use for hadron calorimetry, but the low energy final state particles produced in many reactions at the Mainz beam energies makes development of this capability extremely

desirable. The length of the counters corresponds to the stopping range of 233 MeV for  $\pi^\pm$ , 341 MeV for  $K^\pm$  and 425 MeV for protons. For experiments at Mainz two sub-detector systems will be placed inside the ball (Figure 5). The two multi wire proportional chambers (MWPCs) comprise 480 anode wires in the beam direction with 320 helically wound cathode strips. The detector was previously used with the Daphne detector[9]. The device will give accurate track information for charged particles with a resolution of  $\sim 1^\circ$  in theta and  $\sim 2^\circ$  in phi. A new wire chamber for the Crystal Ball with three proportional chambers will be completed in time for experiments with the upgraded MAMI facility.

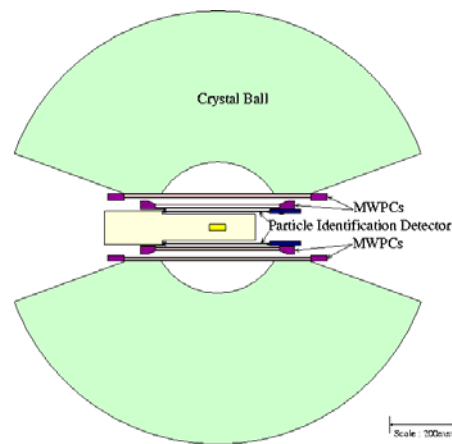

Figure 5. Section through the Crystal Ball showing the MWPC and PID detector subsystems around the liquid hydrogen target.

A 2mm thick segmented plastic scintillator barrel [10] forms the new particle identification detector (PID), which will give a  $\Delta$ -E signal with which to distinguish various charged particle types in the ball. Each scintillator element is 320mm long with one side angled at 15 degrees so that the 24 scintillators can be formed into a barrel with minimal gaps between the scintillator edges. The scintillators are read out at one end by 9mm diameter Hamamatsu Photonics R1635 photomultiplier tubes. The light attenuation of the assembled modules was determined from electron source tests and was found to be  $\sim 0.6$  for particles incident at the opposite end of the scintillator to the PMT.

Preliminary experimental data showing the correlation of energy deposits in the PID with energy deposited in the ball is shown in Fig. 6. The characteristic loci for pions, protons and deuterons can clearly be identified.

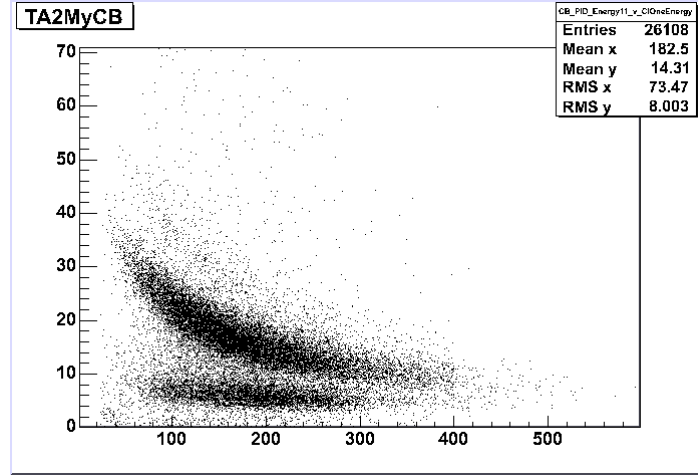

Figure 6. Preliminary experimental data showing the correlation of energy deposited in the PID (y axis – arbitrary units) and the energy deposited in the Crystal Ball (x axis - MeV).

### 3. TAPS $\text{BaF}_2$ calorimeter

The TAPS detector system covers the forward angle region for  $\pm 20^\circ$  which is not covered by the Crystal Ball. This is an important part of the phase space for fixed target experiments with high beam momenta. TAPS consists of 510 hexagonally shaped  $\text{BaF}_2$  detectors each 25 cm long corresponding to 12 radiation lengths. TAPS is a versatile detector system and has been employed at MAMI, GSI, Ganil, CERN and most recently with the Crystal Barrel at Bonn.  $\text{BaF}_2$  scintillator has two scintillation components, a fast component with a decay time of  $\sim 0.6\text{ns}$  and a slow component with a decay time of  $\sim 620\text{ns}$ . The energy resolution for the detector is of similar order to that obtained in the Crystal Ball ( $\sigma/E\gamma \sim 0.59\% \times E\gamma(\text{GeV})^{-1/2} + 1.9\%$  )

New VME based readout electronics for the TAPS detectors have been constructed[11]. The VME modules are piggy-backed onto commercial 12 bit ADC motherboards manufactured by Caen (CAEN V874A). The new electronic design improves significantly on the previous system by allowing the signal information to be digitised close to the detectors which eliminates problems associated with passing analogue signals long distances to the control rooms such as attenuation, shaping and cross talk. Each module of the setup digitises the time, pulse shape and energy information from 4  $\text{BaF}_2$  detectors in parallel.

Figure 7 shows the circuit for one detector channel. The signal feeds two leading edge discriminators (LED1,2), the outputs of which are used for flexible event and trigger selection. The constant fraction discriminator (CFD) gives an accurate timing for the pulse with reduced amplitude dependent jitter or walk. This accurate timing signal is necessary to gate the QAC for the fast component of the scintillator response which is only integrated for  $\sim 20$ ns. The signal from the PMT is fed to 4 separate integration channels (QAC1-4) in which the fast and slow components of the scintillator response are measured with both low and high gain. This gives an accurate determination of the pulse shape over a wide dynamic range and conserves the excellent pulse shape discrimination capabilities of the  $\text{BaF}_2$  detector.

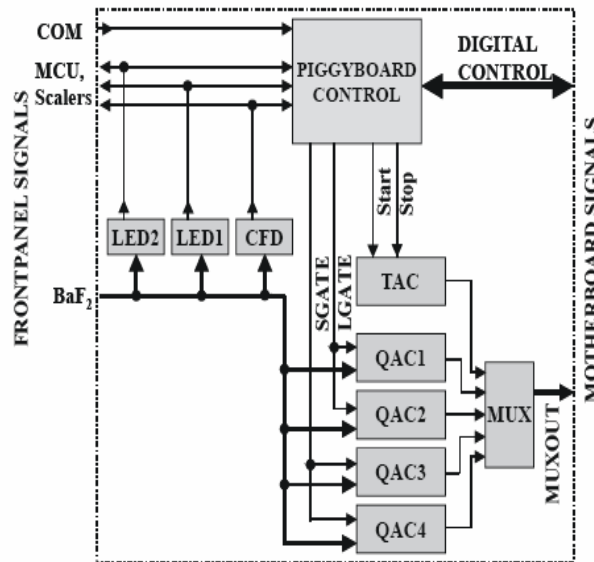

Figure 7. The new TAPS electronics for a single detector channel.

### *Summary*

A new large acceptance calorimeter system comprised of NaI and  $\text{BaF}_2$  scintillators is installed and operational at Mainz. The combination of this system with the upgraded electron beam and tagged photon spectrometer at

MAMI will provide an excellent facility to improve our understanding of hadron and nuclear physics.

### References

1. H. Herminghaus, Proc. of the 1990 Linear Acc. Conf., Albuquerque, N.M., p362 (1990); <http://www.kph.uni-mainz.de>
2. A. Jankowiak et. al., Proc. EPAC2002, Paris (2002)
3. E.D. Bloom and C.W. Peck, *Ann. Rev. Nucl. Part. Sci.*, vol. 33 ,p143 (1983)
4. O. Schwalb et. al, *Nucl. Instr. And Meth.*, A295, p191, (1990); R. Novotny et. al., *IEEE Trans Nucl. Sci* 38 p379 (1991).
5. I. Anthony et. al., *Nucl. Instr. And Meth.*, A301, p230, (1991)
6. A. Reiter et. al., <http://wwwa2.kph.uni-mainz.de/microscope/>
7. D. Krambrich, Dissertation, University of Mainz, in preparation.
8. P. Marciniewski, Fast digital trigger systems for high energy physics, Dissertation 2001, Uppsala, Sweden.; <http://www.tsl.uu.se/~pavel>
9. G. Audit et. al., *Nucl. Instr. And Meth.*, A301, p473, (1991).
10. D.P. Watts et. al., <http://www.physics.gla.ac.uk/~dwatts/pid.html>
11. P. Drexler et. al., *IEEE Trans Nucl. Sci.* 50 p969 (2003).