

DETAIL B  
SCALE 1.000  
(TYPICAL 4 PLACES)

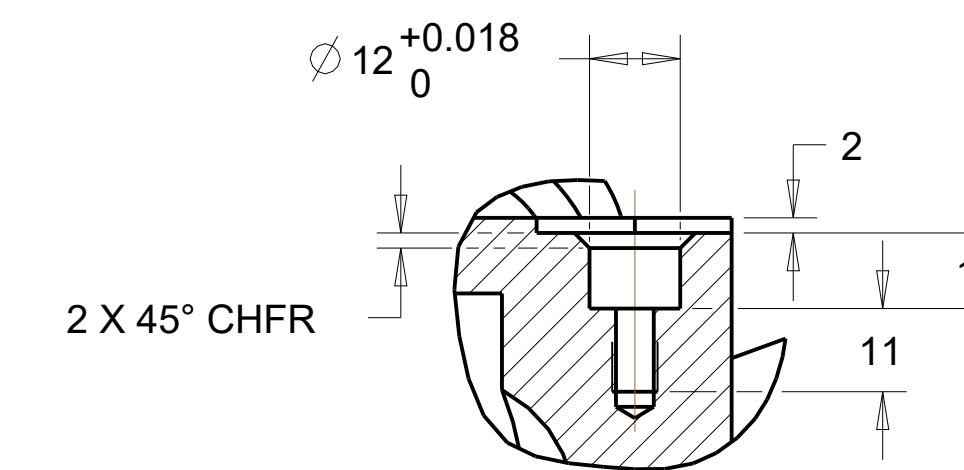

SECTION C-C  
(TYPICAL 6 PLACES)

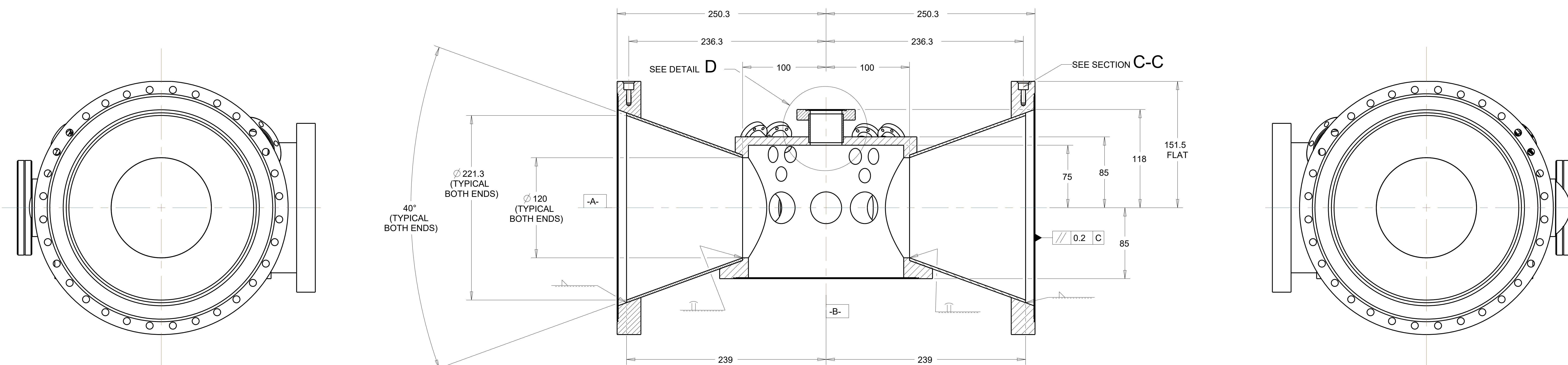

SECTION A-A

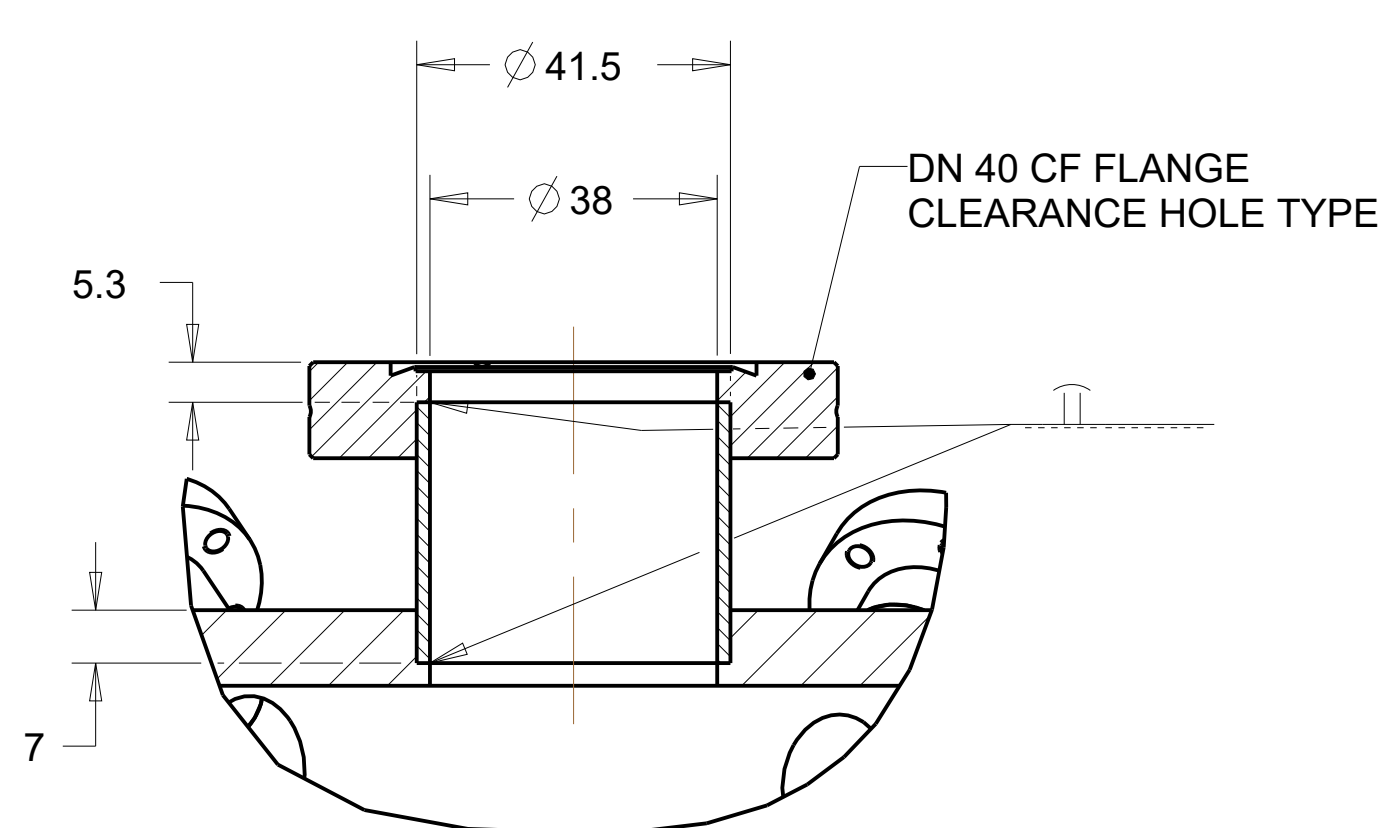

DETAIL D  
SCALE 1.000

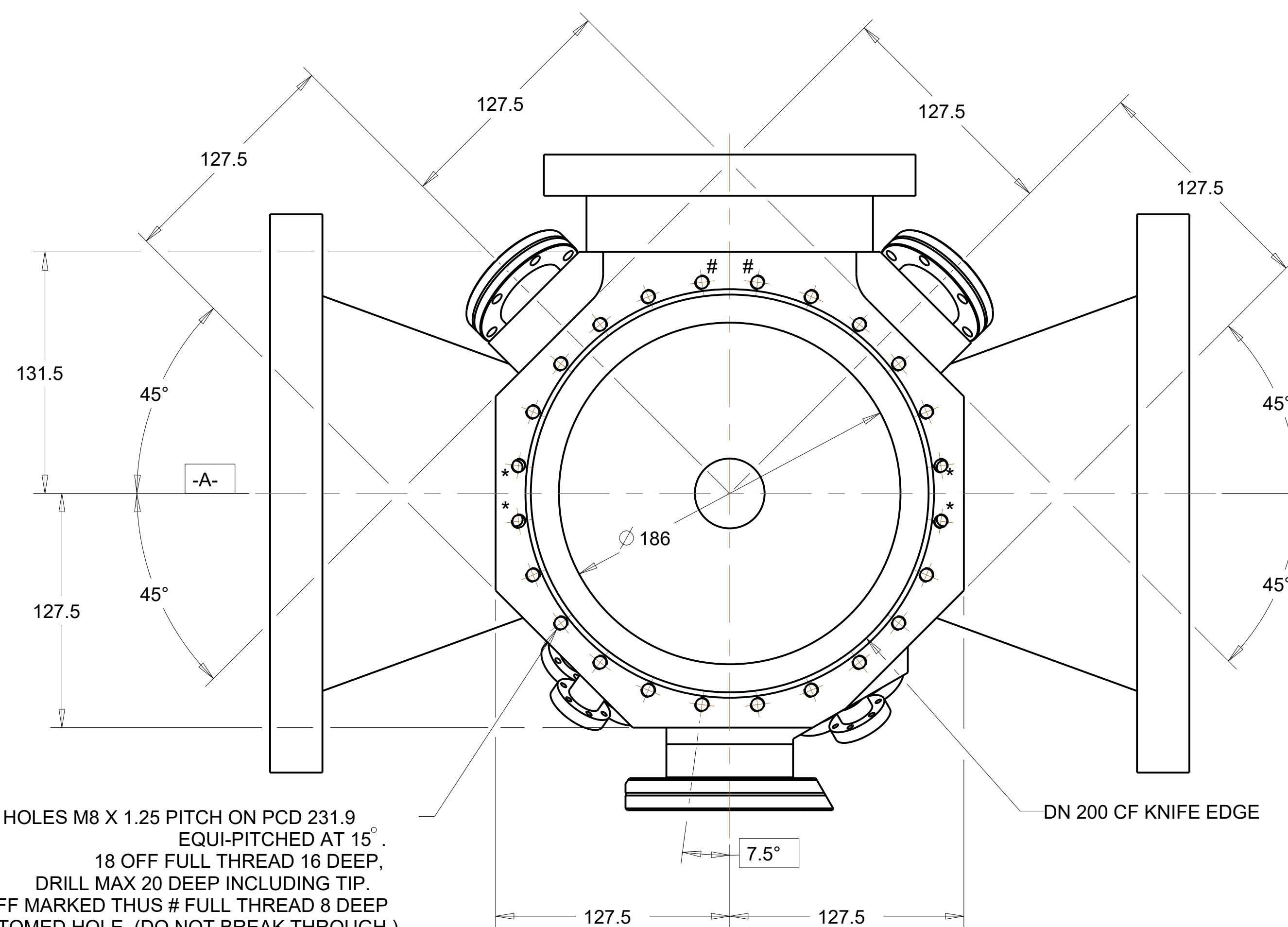

24 HOLES M8 X 1.25 PITCH ON PCD 231.9  
EQUI-PITCHED AT 15°  
18 OFF FULL THREAD 16 DEEP,  
DRILL MAX 20 DEEP INCLUDING TIP.  
2 OFF MARKED THUS # FULL THREAD 8 DEEP  
FLAT BOTTOMED HOLE. (DO NOT BREAK THROUGH.)  
4 OFF MARKED THUS \* FULL THREAD 12 DEEP  
FLAT BOTTOMED HOLE. (DO NOT BREAK THROUGH.)

± 0.25

NOTES:-

1. ALL WELDS ARE TO BE VACUUM SEALING WELDS UNLESS OTHERWISE STATED.
2. ALL VACUUM SEALING SURFACES TO BE FREE FROM RADIAL SCRATCHES AND VISIBLE DEFECTS SUCH AS PITTING, CRACKS AND INDENTATIONS.
3. VACUUM VESSEL IS TO BE MANUFACTURED TO DARESBUARY LABORATORY SPECIFICATION ASTEC-VAC-QCD-spc-002
4. VACUUM VESSEL IS TO BE CLEANED IN ACCORDANCE WITH DARESBUARY LABORATORY SPECIFICATION ASTEC-VAC-QCD-spc-003
5. VACUUM VESSEL IS TO BE TESTED TO A LEAK RATE <math>5e10^{-12}</math> mbar.l/s AND AN OUTGASSING RATE <math>5e10^{-14}</math> mbar.l/s/cm<sup>2</sup> IN ACCORDANCE WITH DARESBUARY LABORATORY SPECIFICATION ASTEC-VAC-QCD-spc-004

ISSUE	DATE	NAME	DESCRIPTION
C	23-Apr-19	D.SEDDON	NOTE 5 CHANGED
B	13-Apr-17	D.SEDDON	NOTE 5 ALTERED
A	18-Jan-16	D.SEDDON	FIRST ISSUE

MODIFICATIONS

UNLESS OTHERWISE SPECIFIED:-		METRIC SCREW THREADS TO BS3643 CLASS 8H/9g		DRAWING PRACTICE AND TOLERANCE INTERPRETATION TO BS308		WELDING SYMBOLS TO BS 499		TITLE	
ALL DIMENSIONS IN MILLIMETRES		TOLERANCES UNLESS OTHERWISE SPECIFIED		MATERIAL	ST. STEEL	DRAWN	D.SEDDON	INTERACTION CHAMBER WELDED ASSEMBLY	
SURFACE TEXTURE TO BE	Ra	MACHINED DIMS ±	0.25	SPEC	316LN	DATE	18-Jun-18	DRAWING NUMBER	NP70-01-2481
MACHINE ALL OVER OR WHERE MARKED	✓	ANGULAR ±	0.151	TREATMENT	NONE	CHECKED	-	ARRGT. DRAWING	NP70-01-2480
REMOVE BURRS AND BREAK SHARP EDGES	✓	DO NOT SCALE	FINISH	NATURAL	APPROVED	-	-	SHEET	1 OF 4 SHEETS SCALE: 0.500 A0

THE UNIVERSITY OF LIVERPOOL  
DEPARTMENT OF PHYSICS

PROJECT ISOL-WP2

TITLE INTERACTION CHAMBER WELDED ASSEMBLY

DRAWING NUMBER NP70-01-2481

ARRGT. DRAWING NP70-01-2480

SHEET 1 OF 4 SHEETS SCALE: 0.500 A0